

TRANSPORT LOGISTICS MILKRUN

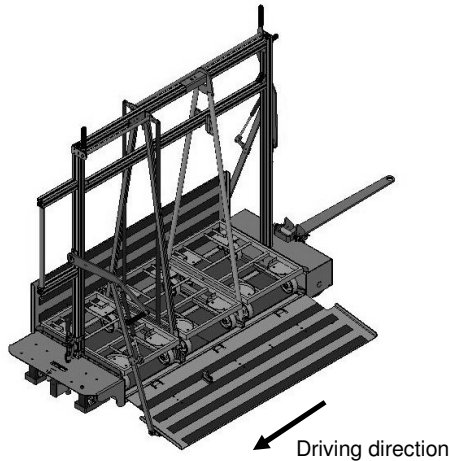

Item no. 138632-3 Zell

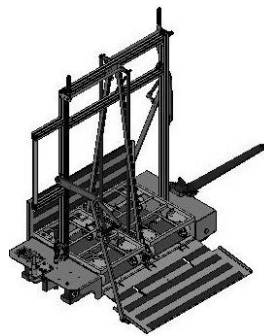
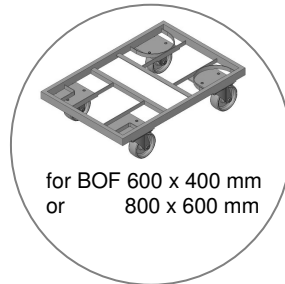

Item no. 138632-3 Zell

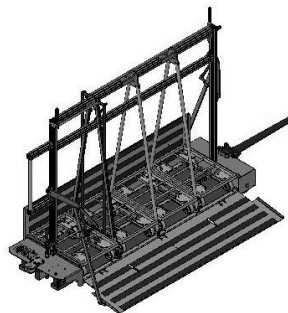

Item no. 138632-4 Zell

Taxi Carts

TRT I

With ramps / trolleys loaded via ramp

For fast and safe indoor transport of trolleys with boxes

Easy handling: Unlock ramps, move trolleys into the taxi cart (resp. Remove them from the taxi cart) and lock the ramp. The taxi cart can continue its routing.

Drawbars adapted to tractor

Smooth-running opening and closing of ramps

Various steering systems possible

Loading from one or both sides possible

Designed for indoor transport only

Max. load capacity 750 kg

Item no.	Product to be transported	Features of wheels	Steering
138632-3 Zell	3 trolleys 600 x 400 mm or 1 trolley 800 x 600 mm and 1 trolley 600 x 400 mm loading and unloading from both sides	Ø 160 mm Polyurethan	trailing steering system
138632-4 Zell	4 trolleys 600 x 400 mm or 1 trolley 800 x 600 mm and 2 trolleys 600 x 400 mm loading and unloading from both sides	Ø 160 mm Polyurethan	trailing steering system
138632-2 Zell	2 trolleys 600 x 400 mm or 1 trolley 800 x 600 mm loading and unloading from both sides	Ø 160 mm Polyurethan	trailing steering system

Other models / dimensions on request.

TRANSPORT LOGISTICS MILKRUN

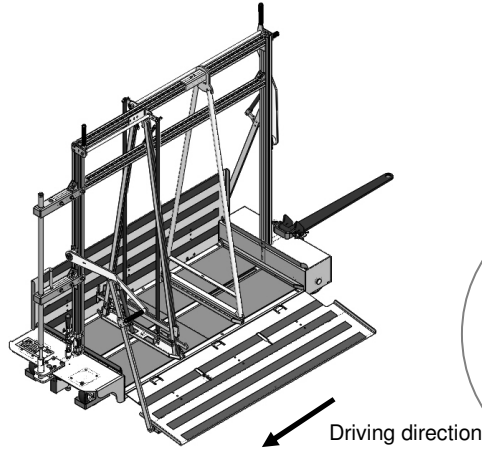

Item no. 201511-3 Zell

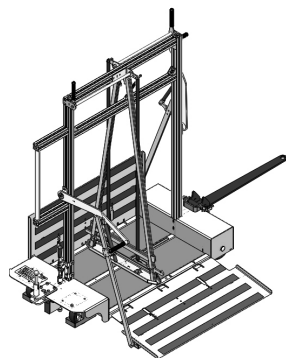
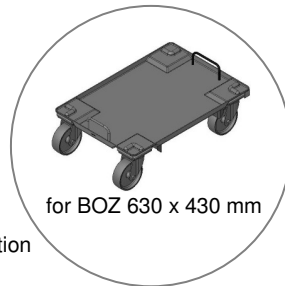

Item no. 201511-2 Zell

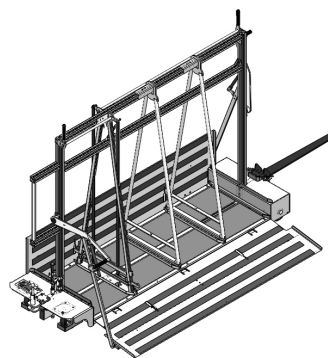

Item no. 201511-4 Zell

Taxi Carts

TRT II

With ramps / trolleys loaded via ramp

For fast and safe indoor transport of trolleys with boxes

Easy handling: Unlock ramps, move trolleys into the taxi cart (resp. Remove them from the taxi cart) and lock the ramp. The taxi cart can continue its routing.

Drawbars adapted to tractor

Smooth-running opening and closing of ramps

Various steering systems possible

Loading from one or both sides possible

Designed for indoor transport only

Max. load capacity 750 kg

Item no.	Product to be transported	Features of wheels	Steering
201511-4 Zell	4 trolleys 630 x 430 mm	Ø 160 mm Polyurethan	trailing steering system
201511-3 Zell	3 trolleys 630 x 430 mm	Ø 160 mm Polyurethan	trailing steering system
201511-2 Zell	2 trolleys 630 x 430 mm	Ø 160 mm Polyurethan	trailing steering system

Other models / dimensions on request.

TRANSPORT LOGISTICS MILKRUN

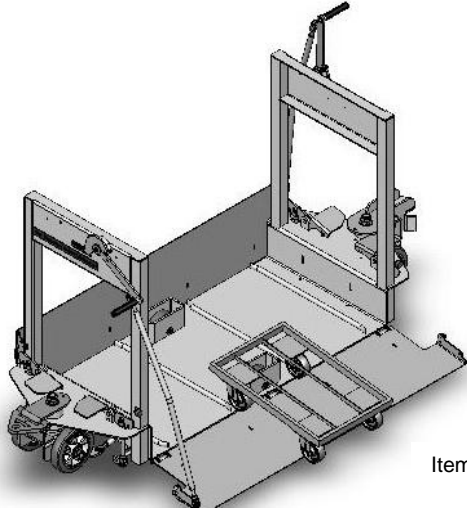

Item no. 133287

Taxi Carts TRT III With ramps / trolleys loaded via ramp

For fast and safe indoor transport of trolleys with boxes

Easy handling: Unlock ramps, move trolleys into the taxi cart (resp. Remove them from the taxi cart) and lock the ramp. The taxi cart can continue its routing.

Drawbars adapted to tractor

Smooth-running opening and closing of ramps

Axle-pivot steering system

Loading from one or both sides possible

Designed for indoor transport only

Max. load capacity 750 kg

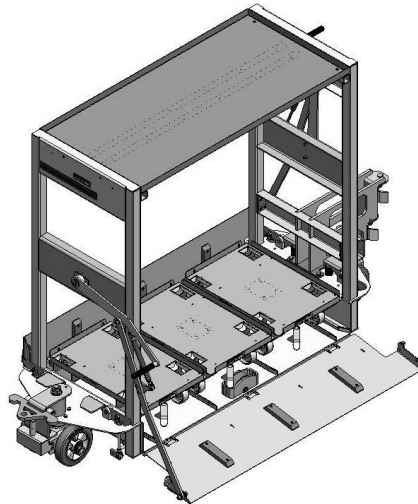

Item no. 205930

Item no.	Product to be transported	Features of wheels	Steering
133287	3 trolleys 600 x 400 mm Model BOF (see chapter TROLLEYS) loading and unloading from both sides	Ø 200 mm Polyurethan	axle-pivot steering system
205930	3 trolleys 610 x 410 mm Model BOF (see chapter TROLLEYS) loading and unloading from both sides		

Other models / dimensions on request.